

The CHR series is perfect for large recreational and commercial facilities.



CHR300

Heart of Central Sewage Collection System

Used for large marinas wanting to offer pumpout in every slip.

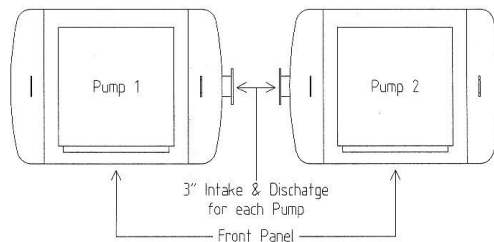

CHR300-2T

Double tank system providing constant flow.

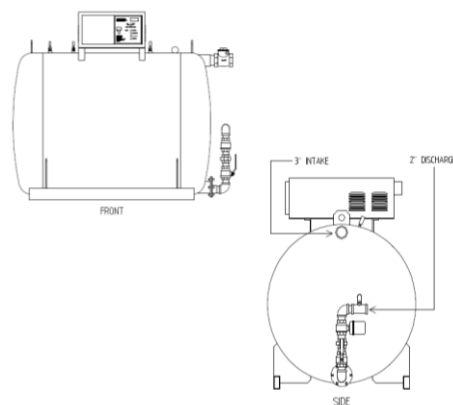

CHR600

Best suited for marinas without sewer connection.

Waubashene, Ontario
CANADA

Tel: 705.538.1495

Toll Free: 800.663.1624
(Canada & US Only)

Fax: 705.538.1776

www.wmwpump.com

STANDARD EQUIPMENT	CHR300	CHR300-2T	CHR600
Motor	3 Hp electric	2 x 3Hp electric	3 Hp electric
Tank	250 US Gal. (946l)	2 x 250 US Gal. (946l)	620 US Gal. (2346l)
Connections	3" NPT Intake & discharge w/ motorized ball valve	3" NPT Intake & discharge w/ motorized ball valve	3" NPT Intake. 2" NPT discharge w/ motorized ball valve
Finish	White or Blue Metallic Top Hot Dipped Galv. Cycle Tank	White or Blue Metallic Top Hot Dipped Galv. Cycle Tank	White or Blue Metallic Top Hot Dipped Galv. Cycle Tank
Accessories (Incl.)	None	None	None

PERFORMANCE SPECIFICATIONS

Max. Suction Lift (recommended)	20 ft (6 m)	20 ft (6 m)	20 ft (6 m)
Max. Suction Distance (recommended)	3000 ft (900 m)	3000 ft (900 m)	3000 ft (900 m)
Max. Suction Performance*	200 GPM (753 l/min)	200 GPM (753 l/min)	200 GPM (753 l/min)
Max. Discharge Head	30 ft (9 m)	30 ft (9 m)	30 ft (9 m)
Max. Discharge Distance (recommended)	3000 ft (900 m)	3000 ft (900 m)	3000 ft (900 m)
No. of Boats Serviceable at Same Time	4	4	4

DIMENSIONS

Width	43" (110 cm)	43" (110 cm)	48" (122 cm)
Length	85" (216 cm)	200" (508 cm)	88" (224 cm)
Height	55" (140 cm)	55" (140 cm)	66" (168 cm)
Tank Diameter	36" (92 cm)	36" (92 cm)	48" (122 cm)
Empty Weight	1700 lbs (775 kg)	3400 lbs (1550 kg)	2500 lbs (1137 kg)
Full Weight	3825 lbs (1740 kg)	7650 lbs (3480 kg)	7775 lbs (3535 kg)
Intake Port	3"	3"	3"
Discharge Port	3"	3"	2" (3" optional)

* performance (in US gallons/minute) through full intake port @ 0 ft vertical lift, 1725 rpm

Standard Features

- Auto cycling between suction and discharge as necessary
- Probe error warning sensor – stops the pump before it gets messy
- Odourless – odour is vented to discharge line
- Easy single switch operation
- Indicator lights to monitor pump mode and tank status
- Power Requirements: 208-230V AC + Neutral, 60Hz (other voltages available)

Optional Equipment Available

- Remote box or galvanized remote stand for multiple intake locations
- Cycle tank galvanizing and dual coating options available
- Token, coin and card reader operation
- Single hand operated suction nozzle

Waubashene, Ontario
CANADA

Tel: 705.538.1495

Toll Free: 800.663.1624
(Canada & US Only)

Fax: 705.538.1776

www.wmwpump.com

All WMW control boxes have been UL approved.

Specifications subject to change without notice.
Oct. 2008

